

Uniclass L41103/4	EPIC D1111/2
C1/SfB  (32.59)  Xt7	
JANUARY 2004	

# Coburn Glassmaster





# Coburn Glassmaster 100™

**The top of the range COBURN GLASSMASTER 100™ offers the ideal solution for architects, interior designers and other specifiers seeking to create a sophisticated and stylish sliding glass partitioning system.**

Easy to use and assemble, COBURN GLASSMASTER 100™ is a cost-effective way of adding distinction to any interior project and is particularly suitable for glass partitioning systems. It offers a contemporary aesthetic look, featuring exposed fittings in 316 grade stainless steel.

COBURN GLASSMASTER 100™ has been developed for use with 10mm or 12mm toughened glass. In tests, the system continued to perform with a weight of 100kgs for over 100,000 cycles without failure.

GLASSMASTER 100™ is supplied in 2.1m or 2.5m track kits.

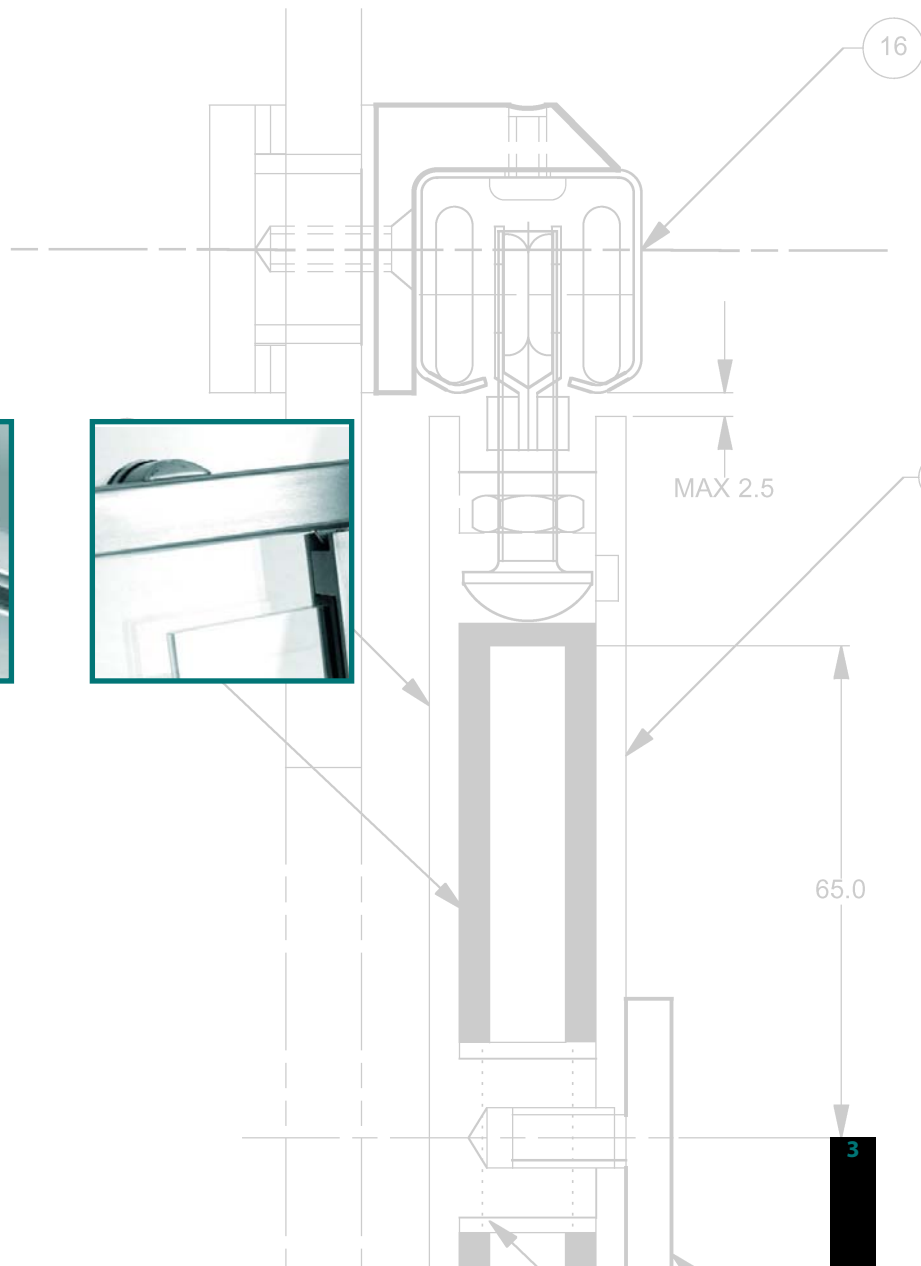

# Engineered for Style and Performance

Based on the highly successful Straightaway 100™ operating system and the result of extensive research, development and testing, COBURN GLASSMASTER 100™ incorporates the latest stainless steel bearings with track, hangers and other fittings in a fine brushed stainless steel finish. Extremely decorative, COBURN GLASSMASTER 100™ is also highly practical in use.

Bracket Assembly

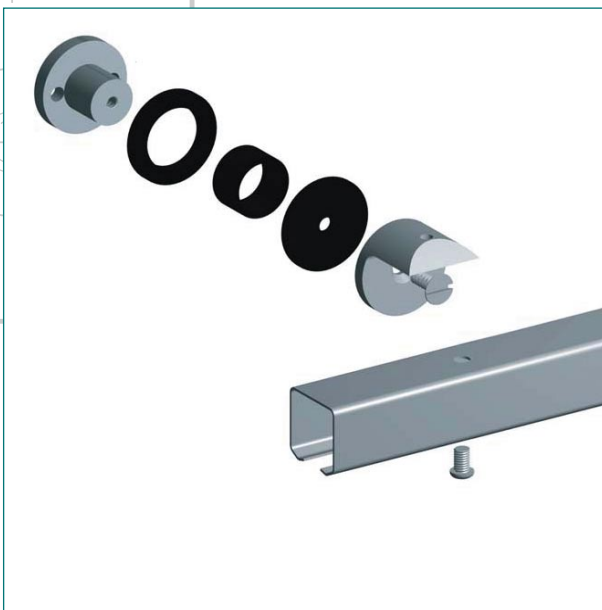

The specially designed track fixing assembly incorporates a decorative bracket, track fixing nut, screws and gaskets for 10mm and 12mm glass. The track is drilled at 400mm centres.

Hanger Assembly

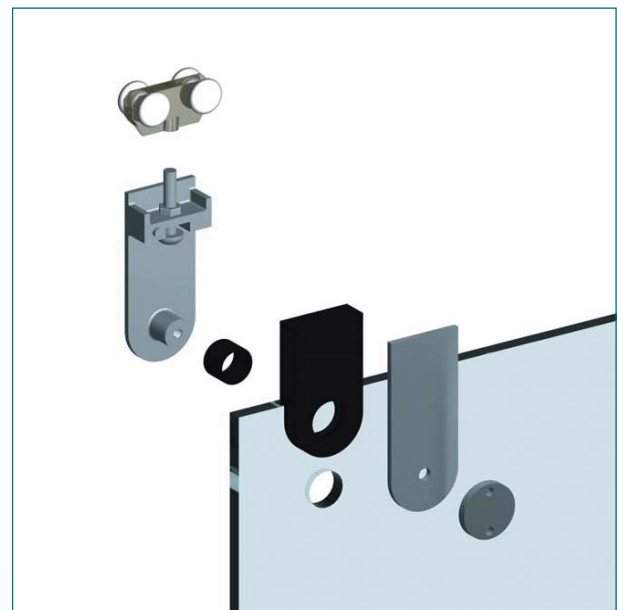

Incorporating a stainless steel body plate and bearings, the hanger is based on proven technology allowing for easy height adjustment. The assembly is completed with the addition of front and back plates, two gaskets and a fixing nut.

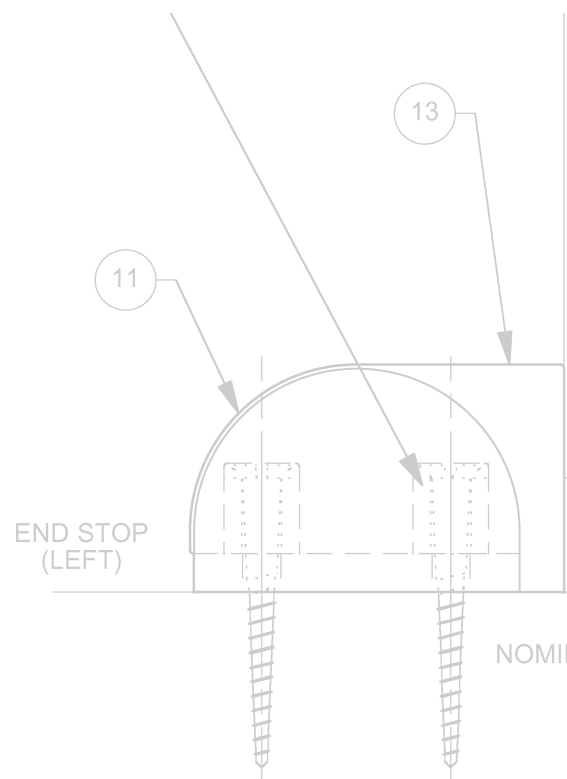
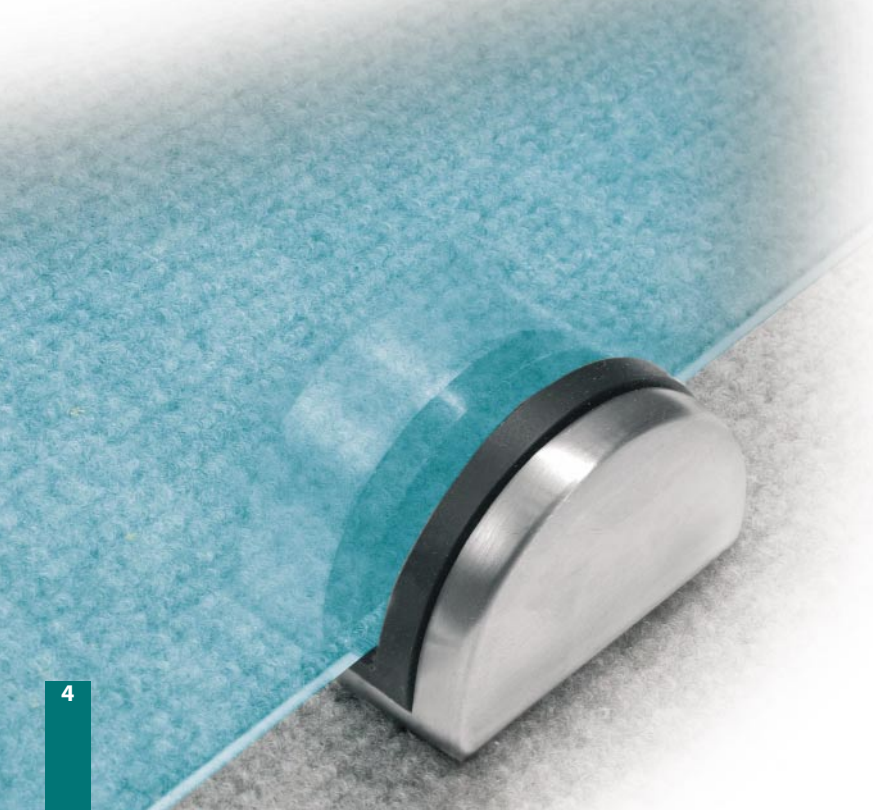



### Track End Cap



The ends of the finished stainless steel track feature specially designed mouldings and track end stops (not illustrated).

Hillaldam Coburn has been a major supplier of sliding systems for over 95 years and COBURN GLASSMASTER 100™ is the result of an extensive research and development programme which identified the need for a range of decorative products reflecting the current desire for ‘honest’ design. Simple in concept, the range includes sympathetically designed door stops and guides.

GLASSMASTER 100™ is supplied with gaskets allowing the system to be used with 10mm or 12mm toughened glass. Also included in each set are 2 hangers, 2 door stops, a door guide and two spanners.

Hangers, incorporating stainless steel ball bearings, lubricated for life, can be adjusted when mounted in the track, although they are supplied to require minimal adjustment.

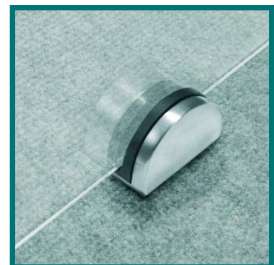
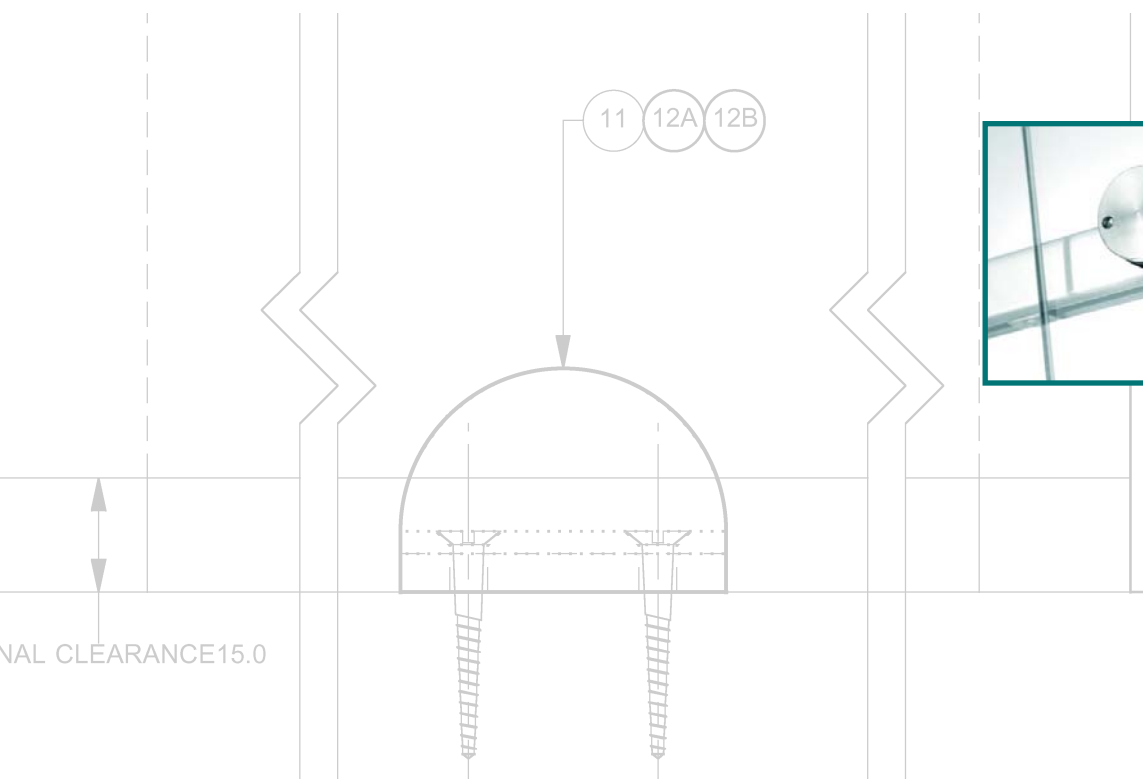

# Specifications

## HANGER ASSEMBLY

Hanger body plates are manufactured in cast 316 grade stainless steel which is finished to give a decorative brushed finish. Trolleys incorporate purpose-made stainless steel bearings and plates and are designed to allow a degree of vertical adjustment when the door is in situ. Two hangers, gaskets and a fixing nut are included in each set.

## BRACKET ASSEMBLY

The bracket assembly consists of a track fixing nut, bracket, gaskets and screws. Brackets must be fitted at 400mm centres. Six brackets are supplied with the 2.1m kit and seven with the 2.5m.

## TRACK

Track, manufactured from 316 grade stainless steel and finished to a decorative finish, is supplied in 2.1m and 2.5m lengths for recommended door widths 1070mm and 1270mm. Track is slotted at 400mm centres to take the bracket assemblies. Ends are finished with moulded rubber end caps, held in place by a small stainless plate secured by an Allen key.

## PERFORMANCE

COBURN GLASSMASTER 100™ has been loaded to 100kg and tested to 100,000 cycles without failure. It is based on the highly successful Straightaway 100 which is widely accepted as being the best system of its type on the market.

## GLASS THICKNESS

COBURN GLASSMASTER 100™ is designed for use with 10mm or 12mm toughened glass. Gaskets to suit both thicknesses are supplied as standard with each kit. The product should only be used with toughened glass and extreme care needs to be taken when fitting to ensure that drilling dimensions are accurate.

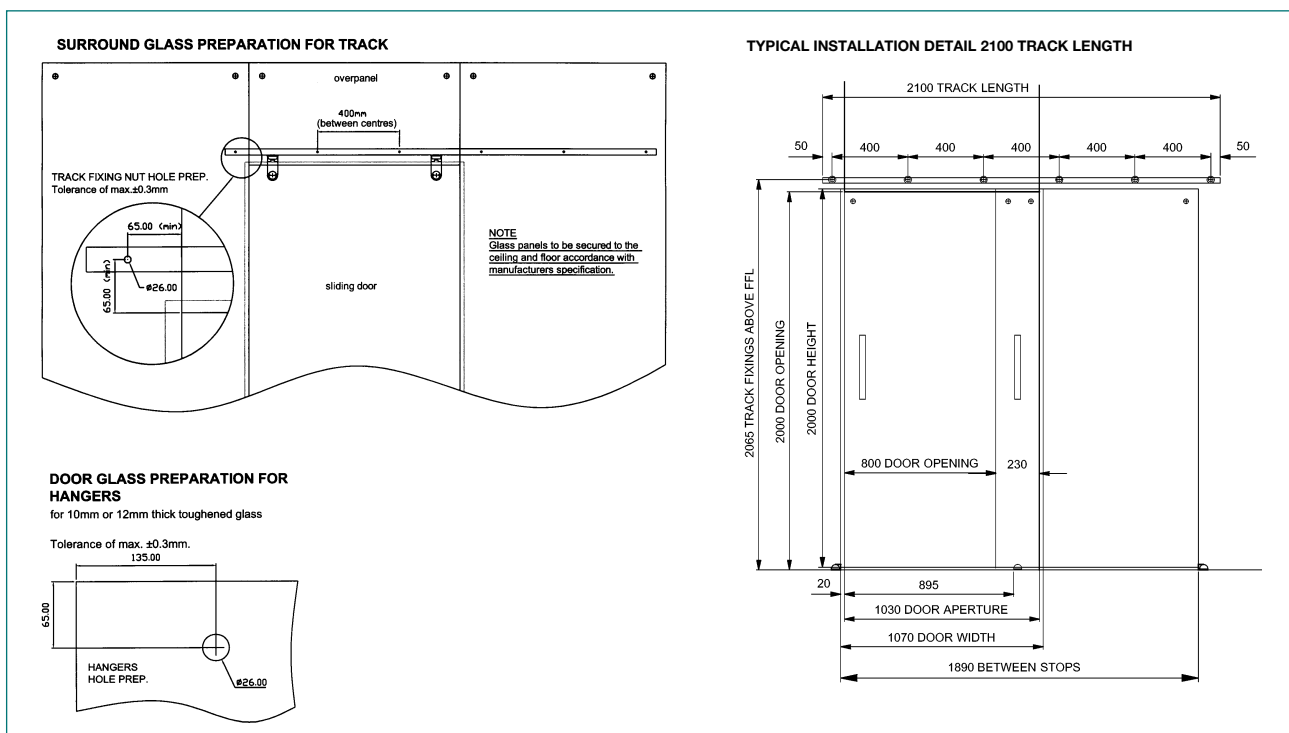

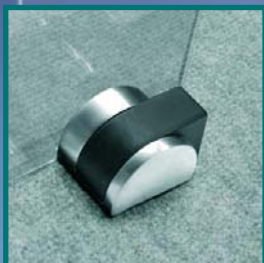

Hillaldam Coburn has a history of commitment to quality and technical developments. Products are always produced to the appropriate British Standards and the company was one of the first in the industry to have operating procedures approved under BS EN ISO 9001.

Constant testing ensures that quality is maintained and a programme of product improvement is regularly reviewed and updated. The company is an active member of the Association of Builders' Hardware Manufacturers. Today Hillaldam Coburn is proud to remain in the forefront of the industry as we take a leading role in working with the British Standards Institute to develop the new European standards (CEN). The following range of literature is available on request:

### COBURN SLIDING SYSTEMS

We also supply a wide range of complementary sliding systems including:

**Straightaway** – top hung and bottom rolling straight sliding systems for commercial and industrial exterior applications

**Stainless Steel Systems** – for applications where greater corrosion resistance is required

**Interior Systems** – for cupboards, wardrobes and interior sliding doors

**Folding Systems** – for interior and exterior applications including timber partitions, folding doors and doors sliding around the corner

**Supplementary Systems** – for specialist applications

### OTHER COBURN PRODUCTS

- Automatic Operators
- Movable Walls and Partitions
- GLIDEMASTER Sliding closures
- Acoustic products for walls and floors

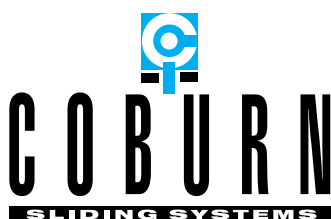

INVESTOR IN PEOPLE



Certificate No. FS 14679

The products designed and supplied by Hillaldam Coburn Ltd are covered by a Quality Assurance system in accordance with BS EN ISO 9001:2000

### HILLALDAM COBURN LIMITED

#### HEAD OFFICE

Unit 6, Wyvern Estate,  
Beverley Way, New Malden,  
Surrey, KT3 4PH, England.

**Telephone:** 020 8336 1515

**International:** +44 20 8336 1515

**Facsimile:** 020 8336 1414

**Sales Freefax:** 0800 616623

**e-mail:** sales@hillaldam.co.uk

**Web:** www.coburn.co.uk

#### SCOTLAND

Unit 25 Baillieston Distribution Centre,  
Glasgow, G69 6UL, Scotland.

**Telephone:** 0141 771 6165

**Facsimile:** 0141 773 1693

**Sales Freefax:** 0800 318904

*The company reserves the right from time to time to make such alterations in design and manufacture as they consider necessary without notice. Drawings, specifications, illustrations, tables and other details are not binding in detail. Conditions of sale are as those published on the Company's tender forms.*

*Handle supplied by Instinct Hardware*